



Brava Shake Installation Guide

BRAVA ROOF TILE
PHONE: 844-290-4196
FAX: 319-343-1038
WWW.BRAVAROOF TILE.COM

This document includes the recommended and suggested installation procedures for the **Brava Shake** roofing material. Brava Roof Tile is the manufacturer of the Brava Shake and all other related roofing products.

Table of Contents

OVERVIEW	1
CAUTION	1
DISCLAIMER.....	1
PRODUCT SPECIFICATIONS	2
GENERAL INFORMATION	3
<i>PRODUCT DESCRIPTION.....</i>	<i>3</i>
<i>ACCESSORIES.....</i>	<i>3</i>
<i>NAIL REQUIREMENTS</i>	<i>4</i>
<i>UNDERLAYMENTS.....</i>	<i>4</i>
<i>METALS.....</i>	<i>4</i>
<i>ROOF DECKING MATERIALS</i>	<i>5</i>
<i>ROOF PITCHES</i>	<i>5</i>
<i>ROOF VENTING</i>	<i>6</i>
<i>SPACING BETWEEN THE SHINGLES</i>	<i>6</i>
<i>COLD WEATHER INSTALLATION.....</i>	<i>6</i>
<i>STORING THE PRODUCT.....</i>	<i>6</i>
<i>VENT FLASHINGS</i>	<i>6</i>
<i>SNOW GUARDS.....</i>	<i>6</i>
<i>ROOF CLEAN UP.....</i>	<i>6</i>
<i>NAILING PATTERN</i>	<i>7</i>
<i>BLENDING OF SHINGLES</i>	<i>7</i>
<i>LAYING OUT CUT SHINGLES</i>	<i>7</i>
<i>HIP & RIDGE.....</i>	<i>7</i>
<i>ROOF JUNCTURE DETAILS.....</i>	<i>8</i>
APPLICATION GUIDELINES	9
<i>ROOF PREPARATION</i>	<i>9</i>
<i>UNDERLAYMENT.....</i>	<i>9</i>
<i>LAYOUT.....</i>	<i>9</i>
<i>VALLEYS.....</i>	<i>10</i>
<i>FLASHINGS</i>	<i>11</i>
<i>ILLUSTRATIONS</i>	<i>12</i>
<i>HIP & RIDGE DETAIL.....</i>	<i>15</i>
<i>HIGH WIND SPECIFICATIONS.....</i>	<i>16</i>

OVERVIEW

The information provided in this manual is for a guideline and a suggested method to install roofing products manufactured by Brava Tile.

As with all roofing materials, acceptable and proven practices should be followed. All application procedures should be done in accordance with local building codes in your area.

The information provided in this manual is strictly a guideline and does not imply responsibility for the final installation of the product. Brava Tile assumes no responsibility for methods of installation or the final results of such installation.

Brava Tile warrants its products for a 50 year period and applies to the product only and not the workmanship of the installed product. The roofing contractors should provide a separate warranty of their own.

Material for this manual has been compiled from various authoritative and professional sources. Many of the methods described and shown herein are sound, time – proven guidelines and standards of good roofing practice that meet the requirements of national and local building codes throughout the U.S. Each geographic area may employ “area practices” that are also sound and time-proven, which by exclusion does not mean to imply that proven area practices are unsatisfactory.

CAUTION

Spacing Requirements

The required spacing for adjacent shingles is a minimum of 3/8”. This will allow for expansion and contraction in various weather applications. This will also give a more natural aesthetic appearance of real shake. **DO NOT** install pieces that are damaged or lifted, as they will not lie down properly.

Color Blending

For better color blending, we suggest you unload the simulated cedar shake from all of the pallets. This applies for both solid and variegated colors.

Caution

Take extra caution due to the fact that this product can be slippery!

Disclaimer

The Brava roofing products manufactured by Brava Tile are intentionally designed to imitate the natural appearance of actual roofing material. This manufacturing process contains a variation within all colors. Care should be exercised by the installer to mix this variation as randomly as possible.

Product Specifications

Profile	Brava Shake <i>Cavity back</i>
Exposure	10"
Weight/Piece (lb.)	1.7 ± 0.2 1.1 (5"); 1.4 (7"); 2.5 (12")
Pieces/Square	169 (total) 57 (5"); 56 (7"); 56 (12")
Lb./Square	312
Height	22" ± 1/8"
Width	5" ± 1/8"; 7" ± 1/8"; 12" ± 1/8"
Pieces/Bundle	12 (4 of each size)
Bundles/Square	14.08
Squares/Pallet	5.96
Pallets/Truck	24
Squares/Truck	143
Fire Rating	Class A or C
Impact Rating	Class 4

Brava Shake	Dimensions	Weight (lb.)	Pieces/Bundle
Starter	12" Length 12" Width	2.0	10
Hip & Ridge	14" Length 6" x 5-3/8" Width	1.9	10
Solid Shingle Accessory	22" ± 1/8" Length 12 ± 1/8" Width	4.25	10

General Information

No special tools required

- Brava Shake can be hand nailed or nailed with a pneumatic nail gun
- Brava Shake can be cut with a standard skill, jig or table saw
- The choice of open or solid sheathing is optional when Brava shake are installed.

Product Description

The Brava Shake is manufactured in three sizes. These sizes are all $22" \pm \frac{1}{8}"$ in length but vary in width. These widths are 5", 7" and $12" \pm \frac{1}{8}"$.

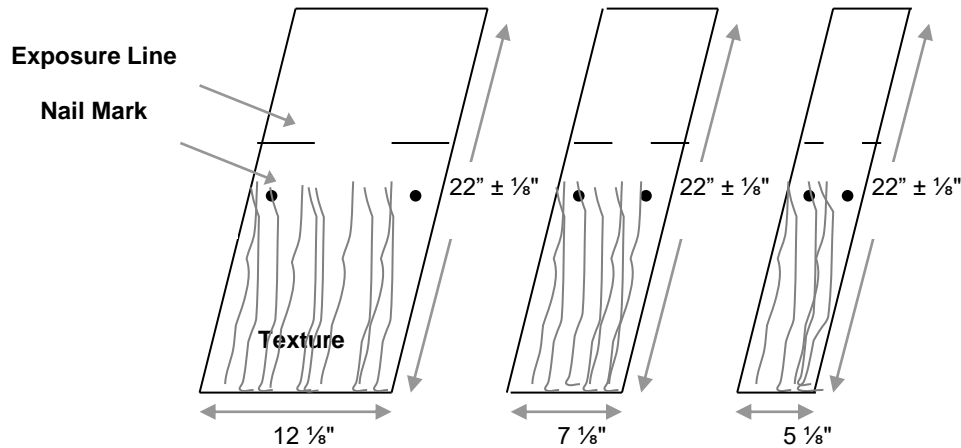

Accessories

Starters

Weight	2.0 lb.
Length	12"
Width	12"

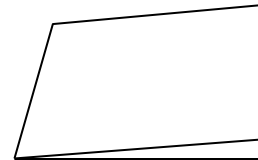

Preformed Hip/Ridge Shingle

Weight	1.9 lb.
Length	14"
Width	6" x 5-3/8"

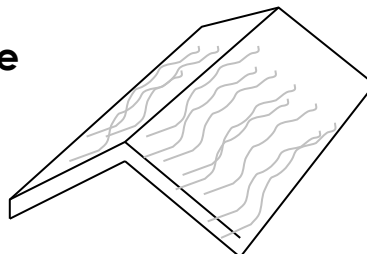

12" Solid Back Shingle Accessory

(Used for Valley cuts, and Rake Edge)

Weight	4.5 lb.
Length	$22" \pm \frac{1}{8}"$
Width	$12" \pm \frac{1}{8}"$

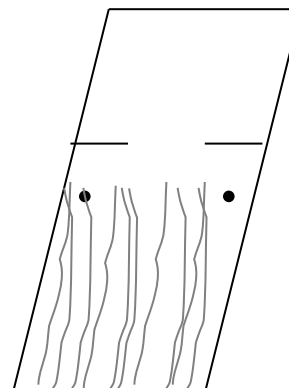

Fastener Requirements

Brava Shake should be applied with two corrosion resistant fasteners, such as stainless-steel type (304 or 316), hot-dipped zinc coated, copper, aluminum or corrosion resistant pneumatic ring shank roofing nails with a 3/8" diameter head and 1 3/4" in length. Nails should be long enough to penetrate the sheathing 1/2".
For eave height 40' or higher use two screws in lieu of nails.

Caution should always be used to insure against over/under penetration. In areas that experience high humidity or other severe climatic conditions, consideration should be given to using stainless steel fasteners and higher-grade accessories.

Underlayments

Ice and Water Shield

- Single layer of 36 mil rubberized asphalt on 4 mil polyethylene carrier sheet
- A 36" wide sheet in all valleys is recommended
- 1 row of 36" wide along all eaves, lap end joints 6" and side joints 3" extended 3' inside the plate line
- Apply around all dormers, roof projections, skylights, etc.
- Always refer to your local building codes
- Ice and water shield is applied directly to the deck without overlapping the shake

NOTE: Ice and water shield should not be installed over the felt.

Felts

- Asphalt saturated and coated organic felt base sheet which meets requirements of ASTM D2626
- Referred to a 30 LB. felt and without perforations
- Secured with 3/4" long galvanized roofing nails
- Felt should be installed per local building codes

NOTE: Minimum requirement on a solid deck is one layer of 30 LB.

Metals

Valleys

- Minimum recommendations
 - 16 oz. Copper
 - 24 - 26 ga. Corrosion resistant metal
 - Stainless Steel*
 - Color Clad Steel*
 - Color Clad Aluminum*

Eaves, gables

- Eave Drip Starter Strips
- Gable Edge Strips

Roof Decking Materials

Solid Deck

- Minimum of 15/32" CDX plywood deck or equal
- Minimum 1" tongue and groove wood decking

Spaced Sheathing

- Usually 1 x 6 boards spaced on centers equal to the weather exposure at which the shakes are to be laid 10" for 22" on roof installations.
- When 1 x 4 spaced sheathing is installed at 10" on center, additional 1 x 4 boards must be installed (i.e. maximum allowable spacing is approximately 3 ½" measured from edge to edge between the sheathing boards.)
- **Check with you local building official for plywood thickness and dimensions.**
- A solid deck is recommended in areas where wind driven snow is encountered.
- Roofing felt system interlay between the shake courses is required for both Class C or Class A fire rating. For Class A, Brava Class A Cedar Shake is required.

NOTE: Felt interlay between courses is not necessary when applied in snow free areas at weather exposures of less than one-third of the total shake length.

Roof Slope

- Minimum roof slope recommended for the application of simulated shake is 4:12, meaning a 4-inch rise in the roof for every horizontal run of 12 inches.
- For roof slopes of less than 4:12, special consideration should be taken for sub roof installation.
- Roof slopes of less than 3:12 are not recommended and should be considered decorative.

Low Slope Roof Details

- The minimum roof slope recommended for the application Brava Shake is 4 in 12, meaning a 4-inch rise in the roof for every horizontal run of 12 inches. Special application procedures should be followed to successfully install shake shingles to solid sheathed roofs of lower slope.
- Special waterproofing sheets, such as ice and water shield, may be used as the underlayment. These sheets will help alleviate moisture problems at nail penetrations. Next, the shake shingles are applied in the normal manner with a starter course at the eave and felt interlays between each course of shingles.

Standard Roof Slope Details

- Type 30 Asphalt saturated felt interlay is required between courses of shake shingles on slopes of 6/12 or lower, and is recommended for slopes greater than 6/12.

Roof Venting

For every 300 feet of attic floor space, you will need one (1) square foot opening in the roof. Fifty percent (50%) of this needs to be at the eave line. Venting is important and needs to be thought out thoroughly.

NOTE: If screening is involved, opening areas should be doubled.

Spacing Between Shake

The spacing between adjacent shingles should be a minimum of 3/8". This will allow for any movement of the roof deck and expansion/contraction of the materials. Side laps should be 1 1/2" and no two joints should be in direct alignment.

Cold Weather Installation

It is recommended that the Brava Shake not be installed in temperatures below 20° F. Special consideration should be given for cold weather installation regarding items such as ice and water shield and felt underlayment. **Be sure to follow the manufacturer's installation requirements for all other applications and to refer to local building code requirements.**

Note of Caution: The shingles can be slick and safety methods need to be enforced.

Product Storage

For better and easier installation, the Brava Shake shingles need to be stored on a flat surface. The shingles can become twisted or bent when stored on an uneven surface. Twisted or bent shingles can cause an initial appearance concern and a possible problem with blowing snow and rain, and therefore should **NOT** be installed.

Vent Flashings

Normal type of roof jacks or flashings can be used. A lead jack for plumbing pipes is recommended. Permanent types of materials should always be used.

Snow Guards

Due to the textured surface of the shingles, snow may slide off rather easily. The need for snow guards will increase in areas with above average snowfall. Be sure to follow the snow guard manufacturer's installation specifications for the correct spacing and always refer to local building code requirements.

Roof Clean Up

In areas of hips and valleys where there will be a greater cutting of the shingles, it is recommended that these areas are swept off and the cuttings removed from the roof surface. This is for safety reasons and to keep the cuttings from stopping up the gutters and down spouts.

Nailing Pattern

All shingles will be nailed with two nails, as per Brava's instructions. Two nails will be used on the pre-marked nail hole indicators for a 10" exposure.

Blending of Shingles

It is recommended that the installer load the roof with the shake out of all the pallets, rather than from a single pallet. Good blending is the responsibility of the installer.

Laying Out Cut Shingles

When starting out or finishing with a cut piece of shake, the cut edge should be installed inward. The manufactured edge should always be installed to the outside (or the gable edge) of the roof. This is for appearances only. (See diagram below.)

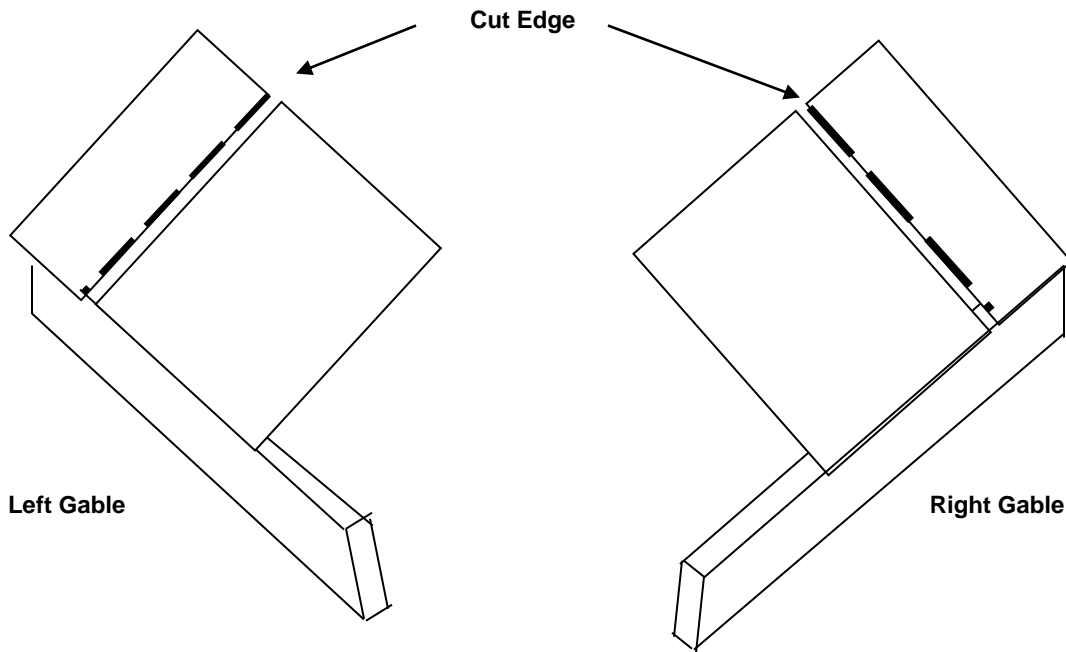

Hip & Ridge

Hip and ridge shingles should be nailed with an overlap exposure equal to that of all preceding courses of shingles.

Roof Juncture Details

When metal flashing is employed, it should be no less than 26 gauge galvanized steel (or equal) painted on both sides with a good metal or bituminous paint after forming to maintain the integrity of the galvanized coating.

Convex Juncture

- The type of metal flashing should be installed to cover the top four inches of the wall and the bottom 10 inches of the roof slope before the final course of shake shingles is installed.
- A starter course is then applied at the eave, with a 1 ½" overhang of the wall surface.
- The roof can then be completed in the normal manner.

Concave Juncture

- This metal flashing is similar to the convex type and is installed to cover the top of the roof slope and the bottom four inches of the wall before the final course of shake shingles is installed.

Application Guidelines

Brava Shake can be applied in a variety of patterns. The most common pattern is a single straight-line course. Following are general guidelines for this application.

Roof Preparation

Inspect all areas of the roof to be shingled to assure that:

- 1) Surface area is uniform, smooth, sound, clean and free of irregularities.
- 2) Even though metal flashing and other specialty flashings may not be the responsibility of the roofer, these must be in place prior to the installation.
- 3) Work by other trades, which penetrate the roof plane, is completed.

Underlayment

- 1) Install Ice and Water Shield at all eaves, valleys and around projections in lieu of any felt underlayment.
- 2) Felt underlayment should **not** be placed under the ice and water shield, but should overlap the ice and water shield no less than 2".
- 3) If ice and water shield will be your main underlayment instead of felt, it should be installed directly to the deck.

Layout

Brava Shake can be applied in a variety of patterns. The most common of which is a single-straight line course of shakes.

- 1) The starter course will be applied using the starter pieces. These tapered starter pieces measure 12" x 12". The starter course should project 1/2" beyond the fascia board at the eave and 1" at the gable end.
- 2) Each starter should be nailed 6" up slope from the thick end and in 1 1/4" from each outer edge.

Nail Pattern

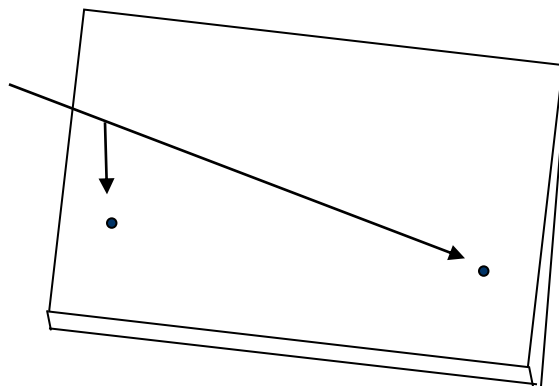

- 3) A 3/8" spacing between starter pieces is necessary.
- 4) If a starter piece is needed to be cut to complete the starter course, place factory edge to the outside.

- 5) Now start the first course. The first course of shake should be nailed over the starter course in such a manner that the joints in each course are not less than 1 ½" apart. This is a recommended "side lap."

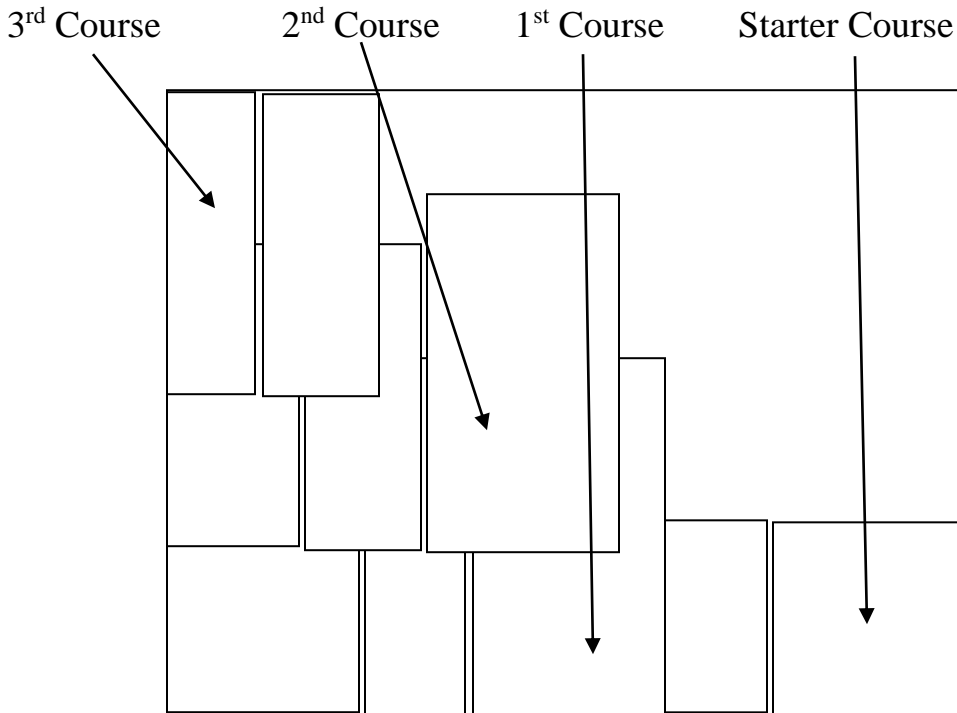

Valleys

Either an open or closed valley design can be used.

Open Valley Design

With an open valley design, leave a minimum 4" opening at the top of the valley, graduating ½" per 8 lineal feet down slope. For roof slopes of 4:12 or greater, "w" valley flashing should have 1" center crimp, painted, galvanized steel, aluminum, copper or stainless steel and extend a minimum of 10" on each side of the valley centerline. For roof slopes less than 4:12, valley flashing should extend not less than 14" each side.

Closed Valley Design

Closed valley flashings are 2 1/2" center crimped, extending 10" out from centerline.

Flashings

Flashings should be used around all roof projections, such as walls, chimneys, dormers, parapets, vent pipes, skylights, etc. Proven durable flashing materials are copper, tin, lead, galvanized iron and stainless steel.

NOTE: When dissimilar metals are placed in contact with one another, galvanic action will result which can cause electropositive metals to deteriorate. One way this can be avoided is by placing strips of sheet lead between the two metals.

Illustrations

The following illustrations show proper flashing procedures for shake shingle roofs.

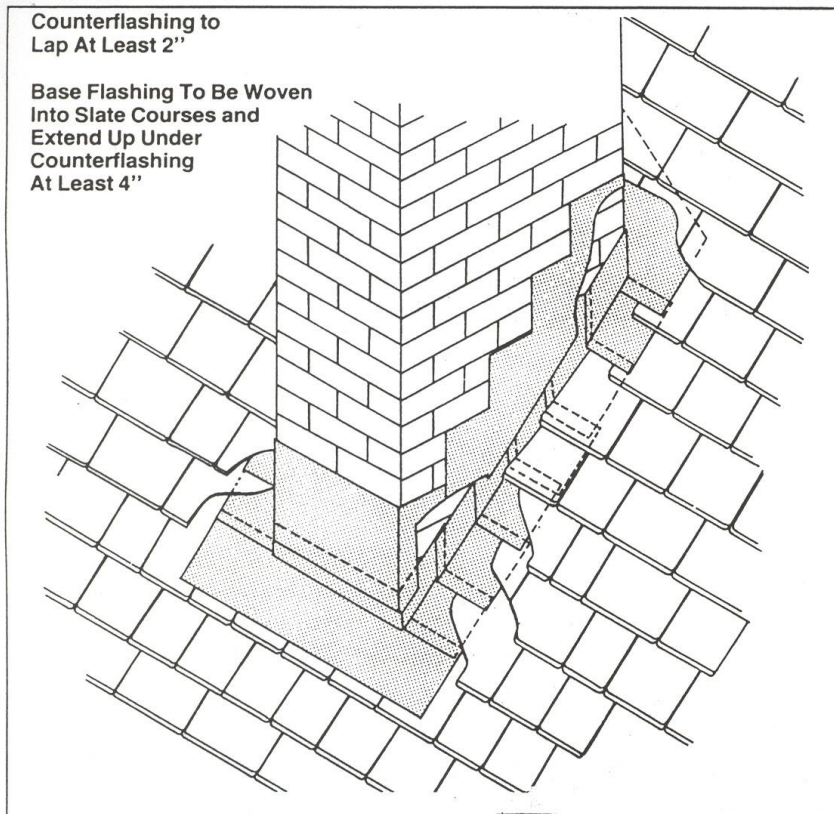

Built-In Base Flashing for a Chimney

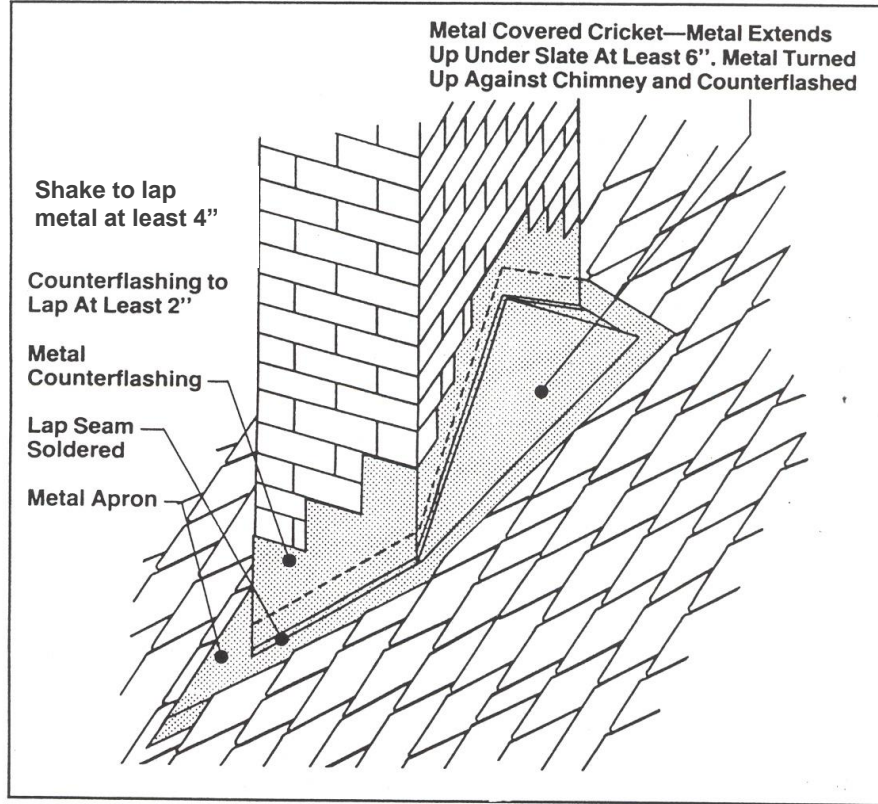

Flashing for a Chimney

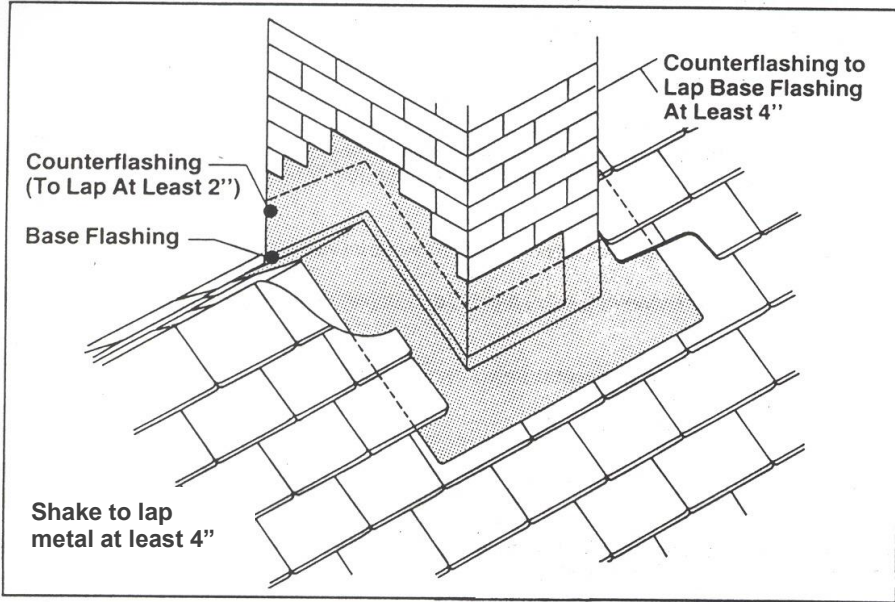

Flashing for Chimney on Ridge

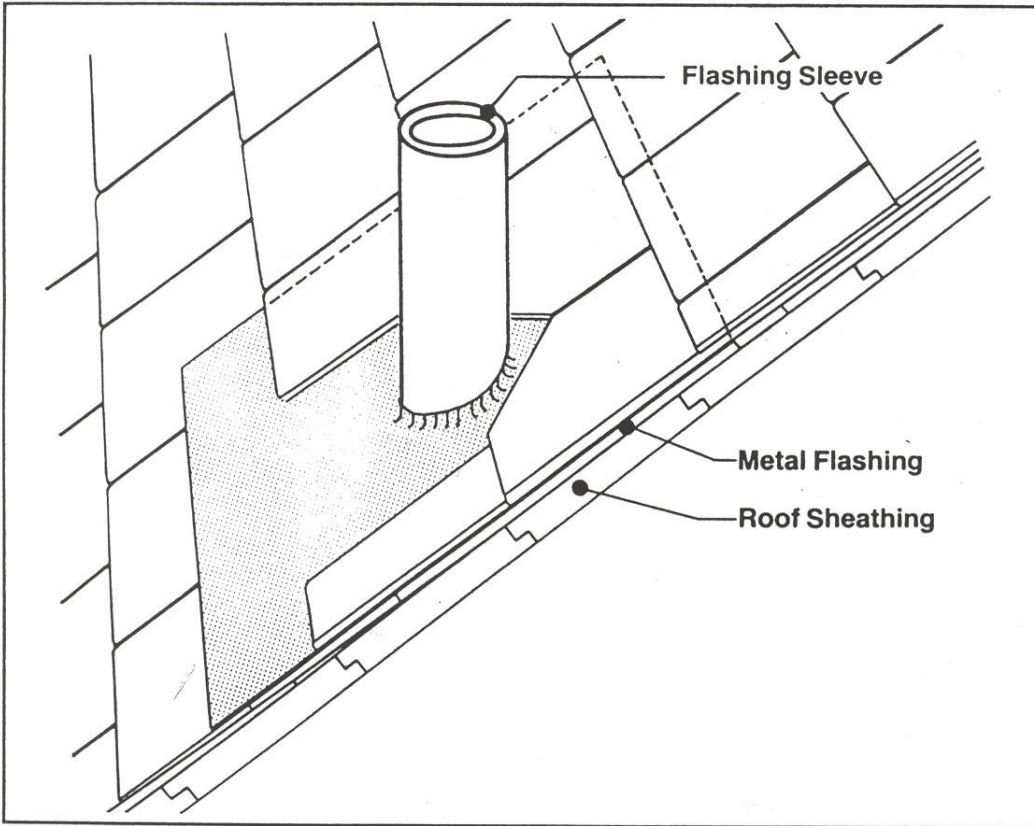

Flashing for Soil Stack

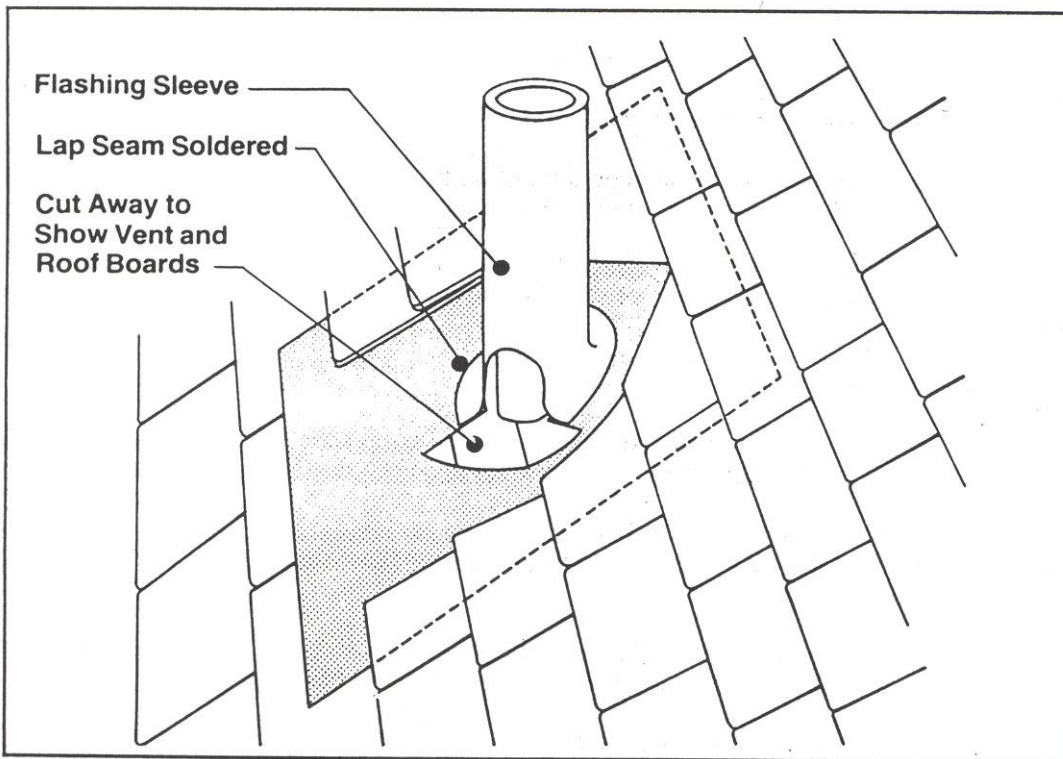

Flashing for a Vent Pipe

Hip & Ridge Detail

- Trim the hip shingles to fit as tight as possible. Install an 8" wide strip of 30 lb. felt minimum over the center of the hip.
- Nails should penetrate decking 1/2".
- When pre-formed hip & ridge shingles are used, place nails at nail locator marks. Fasten hip shingles with 1 nail each on each side. Maintain a 3" head lap

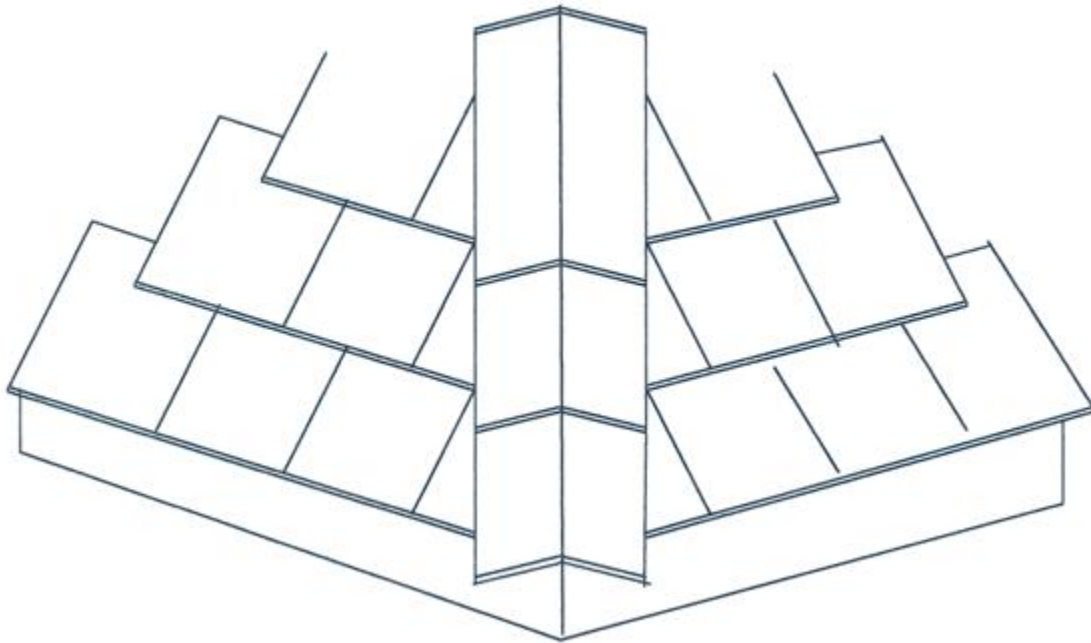

High Wind Specifications

Roof Decking Materials

Solid Deck

- Minimum of 1/2" plywood nailed at perimeter 6" on center, in the field 6" on center and on seams 4" on center.

Underlayment

- Install Ice and Water Shield at all eaves, valleys, and around projections that are greater than 12" x 12" (recommended)
- Felt underlayment should not be placed under the ice and water shield, but should overlap the ice and water shield no less than 4". Side laps should be no less than 6".
- Roofing felt 30# Asphalt Saturated organic felt paper nailed with 1 tin tab per nail, 1 1/4" smooth roofing nail, at 6" oc on all seams and in the field 12"oc staggered 12".

Fastener Requirements

Brava Shake should be installed with two 1/8" dia. X 1 3/4" ring shank roofing nails for 110 mph. Brava Shake should be installed with two 1/8" dia. X 2" ring shank roofing nails for 288.5 PSF design pressure.

Caution should always be used to insure against over/under penetration. In areas that experience high humidity or other severe climatic conditions, consideration should be given to using stainless steel fasteners, and higher grade accessories.

Layout

1. The starter course should project 1/2" beyond the fascia board at the eave and 1" at the gable end. The starter should be nailed with two 1/8" dia. X 2" ring shank roofing nails.
2. From both ends, position starter pieces and snap a horizontal line from the tops of the starters between these two points. Next snap a vertical line from eave to top ridge. These chalk lines will insure that the shakes will be started true and plumb. More horizontal and vertical lines may be snapped to insure the shake will stay true and plumb throughout installation.
3. Initial starting points may be from the left side, right side or center of the area to be roofed. A minimum spacing of 3/8" between all shakes is required.
4. Solid shakes may vary in size. Do not use them to establish your roof layout. They are an accessory part. Be sure to snap proper lines to initialize and ensure proper layout.
5. One method of starting is to locate the center of the roof area to be covered. Snap a vertical and horizontal line at this point. Begin by placing a starter tile on the right and left side of the vertical line maintaining a 3/8" spacing and continue to both ends. Starter pieces should be applied with the tapered edge (thin edge) at the top of the starter course.
6. The exposure of the shake is to be no more than 8".
7. Now start the first course. The first course of shake should be nailed over the starter course in such a manner that the joints in each course are not less than 1 1/2" apart. This is the recommended "side lap."